

Portable cordless dot peen machine e-MARK EVO



The mark of quality

ALL-IN-ONE
PORTABLE

HIGH
PERFORMANCE

ROBUST



e-MARK EVO Micro-percussion marking gun

High-performance. Portable. Built to last.

The **e-MARK EVO** is a portable, cordless, all-in-one marking machine that uses micro-percussion technology. Designed to mark both plastics and steels up to 62 HRC, it **combines power, precision, and versatility.**

Robust, lightweight (3.5 kg), and ergonomic, the e-MARK EVO is perfectly suited to all industrial environments. Its tungsten carbide stylus guarantees precise, durable, and reliable marking of your text, logos, or data matrix codes.

0A38 1340 83



Marking window:
60 x 25 mm

LED lighting

Integrated programming interface

Interchangeable front face plate

Industrial membrane keyboard, resistant to harsh environments

USB connectors

Body and handle made of cast aluminum for strength and durability

Mounting point for balancer

36 V battery with charge indicator



XL

Also available in XL version with 120 x 40 mm window

Ergonomic design for immediate handling

Compact all-in-one machine:

- 100% autonomous solution, integrating the control unit with screen
- Lightweight and balanced, can be used with one hand for easy marking of your small parts
- Quick programming thanks to the onboard HMI and integrated keyboard
- Complete pack including:
 - Carrying case
 - 2 batteries + charger for continuous use (Battery charges in 1 hour)



Various front panels available*

- Quick tool-free replacement
- Suitable for all part geometries (bulky, cylindrical, small surfaces)



1 Front panel with non-slip coating

2 Reduced and adjustable front panel

3 Magnetic front panel



*Ability to design custom-made front panels



Mark your items easily and reliably

- Create your marking files directly on the e-MARK EVO or from your workstation using the FILE EDIT software
- Operator/supervisor mode allows critical settings to be locked
- Barcode reader mode allows the file and content to be marked to be selected automatically, eliminating the possibility of input errors
- History function with duplicate detection, alerting the user in case of repeated serial numbers

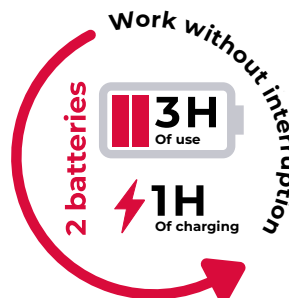

Designed for heavy-duty use

- Work without interruption thanks to two high-capacity batteries
- Mark materials up to 62 HRC hardness
- Choose your machine according to your applications:
 - Standard version for fast and accurate marking
 - **Booster version:** Markings are still fast and precise, but also deep, visible after painting or surface treatment



Technical specifications and accessories

Application examples

Technical data:

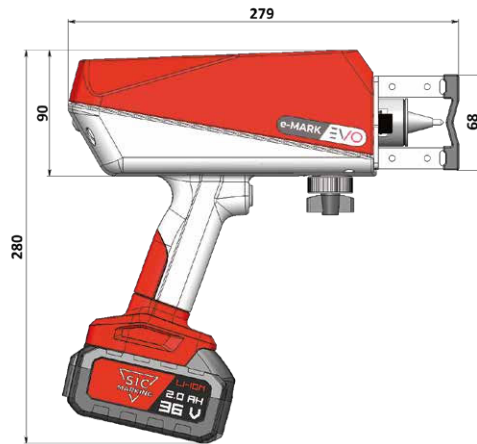
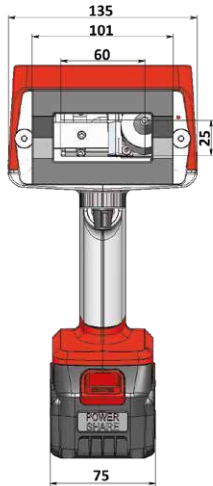

*Example shown with standard front panel

| | |
|-----------------------|--------------------|
| Power supply | 36 V battery |
| Battery charging time | 1 h |
| Battery life | 3 h |
| Marking window | 60 x 25 mm |
| External dimensions: | 279 x 280 x 135 mm |
| Weight | 3.5 kg |
| Stylus | Tungsten carbide |
| Memory space | Over 2,000 files |

Available accessories:

Barcode Reader



Column base



Interchangeable Front face plates

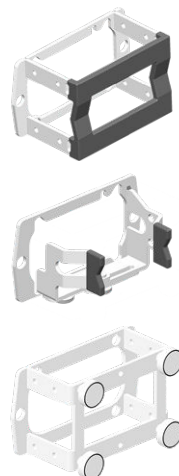

Booster option

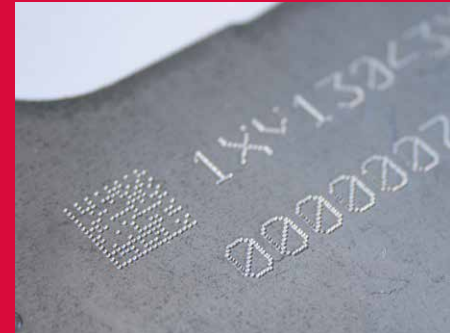

The 8 key SIC MARKING services



Personalized advice for the best choice of technology

Laser, micro-percussion or scribing? Our experts will help you identify the marking technology best suited for your requirements, thanks to our wide range of solutions.



Customized solutions tailored to your needs

We develop customized products that are perfectly adapted to your industrial processes and requirements.



Feasibility studies and technical tests

We carry out rigorous feasibility studies and tests to validate each stage of your project. Engineering tests are also available.



Complete training for your teams

Our specialists train your teams in the use of your equipment to ensure autonomous and effective control.



Assistance during commissioning

Our local teams are on hand to support you during the commissioning of your machine, facilitating smooth and rapid integration into your day-to-day operations.



Technical support and after-sales service

Responsive after-sales service and dedicated technical support members are at your side for assistance for the supply of spare parts and consumables.



Retrofit solutions for sustainable performance

We offer customized retrofit solutions to extend the life of your machines: backward compatibility with updated components, complete modernization or equipment takeover.



Global support with local expertise

With 10 subsidiaries and a worldwide network of distributors, we offer global resources combined with local support to take charge of your projects from design to installation.

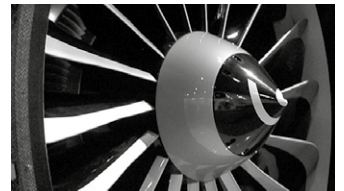

SIC MARKING CANADA
2 Rue de Lauzon #35,
Boucherville, QC, Canada
+1 450-449-9133

info@sicmarking.com
<https://www.sic-marking.ca>

