

# DOT PEEN PORTABLE MARKING SYSTEM

## e10 p123



### + CONFORTABLE

- Reduced vibration during marking
- Minimum noise
- Rear support surface for high stability
- Reduced weight

### + POWERFUL

- Constant quality and precision
- Marking speed
- Powerful impact force
- Great depth of marking
- Hard parts marking up to 62 HRC

### + CONVENIENT

- Simple adjustment of the front panel thanks to a system with 4 predefined positions
- Handle foot designed to guarantee good stability

### + ROBUST AND RELIABLE

- Light and robust cast aluminium body and handle
- Rigid and stable, perfectly adapted to an industrial environments

- 👍 **LARGE MARKING AREA**
  - 120 x 25 mm - 4.7 x 1 in
  - 120 x 40 mm - 4.7 x 1.6 in



+ Booster Option available

## APPLICATIONS



## DOT PEEN MARKING EXAMPLES

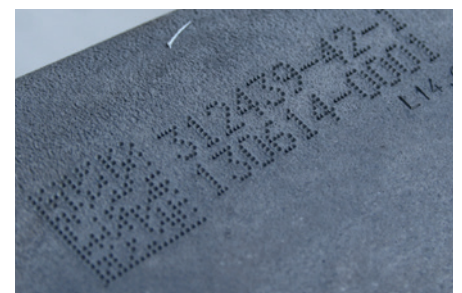

# TECHNICAL & MECHANICAL FEATURES

## e10 p123

Marking window	120 x 25 mm / 120 x 40 mm - 4.7 x 1 in / 4.7 x 1.6 in
External dimensions	217 x 277 x 218 mm / 217 x 317 x 218 mm - 8.5 x 10.9 x 8.6 in / 8.5 x 12.5 x 8.6 in
Weight	3,7 kg - 6.6 lbs
Stylus	Tungsten carbide
Machine / controller cable length	7,5 m - 23 ft (10 m - 32.8 ft and 15 m - 49.2 ft optional)
Cylindrical part marking	V-shaped front plate

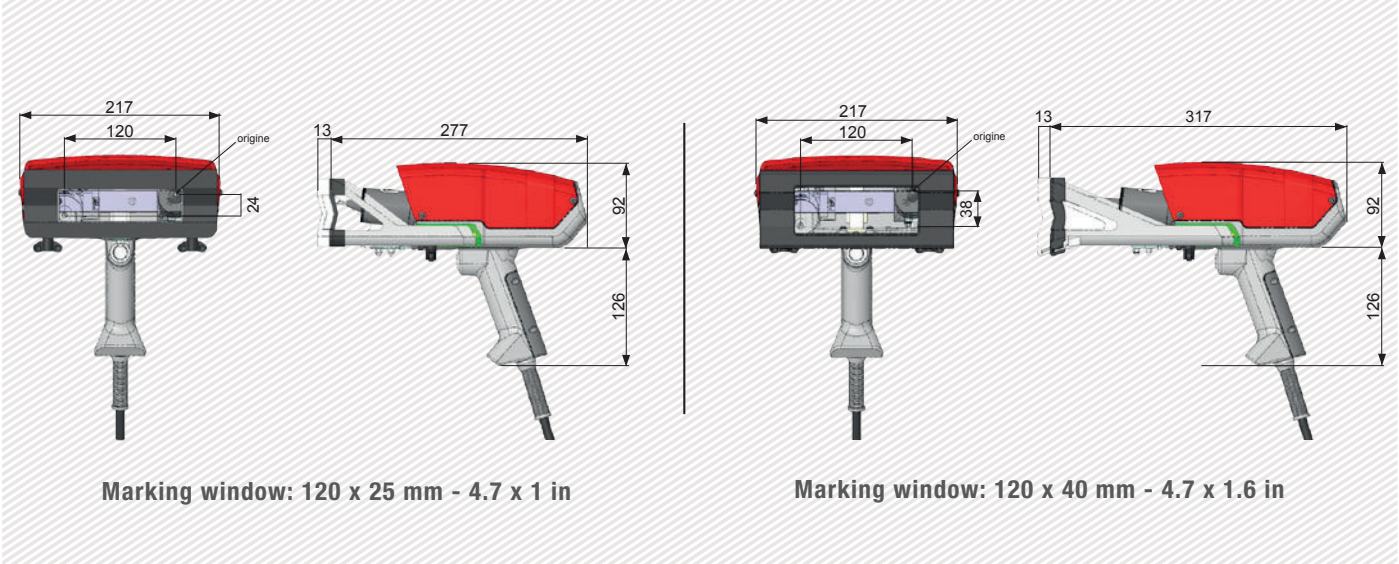

# OPTIONS



Cart on battery



Hook and balancing system



Column base

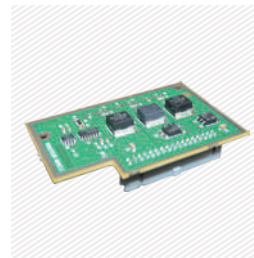

Booster card for deep marking (for 120 x 25 mm)



Magnetic front plate



Maintenance kit



Wireless barcode reader



Datamatrix reader



Rotary axis

Please consult us if a specific configuration is not published in the table attached.

SIC Marking designs customized and turnkey solutions for all industrial sectors. Our design offices produce machines in compliance with your specifications and your industrial standards.

# E10 CONTROL UNIT

## The e10 controller

- Color screen
- USB Port: to easily upload / download your marking files
- Fully programmable
- Standalone (no PC needed)
- Membrane protected industrial Keyboard
- IP40 waterproof box (no opening or fan)



+ Multiple connectivities



+ Color screen



+ USB Port



## Technical & electronic features

e10 Controller	
Dimensions	322 x 380 x 112 mm - 13.7 x 15 x 4.4 in
Weight	5 kg - 11lbs
LCD screen resolution	480 x 272 pixels
Keyboard	Qwerty integrated, protected by membrane
Power	300 Watt
Power supply	Single phase, 85 to 260 VAC, 50 to 60 Hz
Controlled axes	2 (optional 3rd / 4th axis card)
Operating temperature	From 5 to 40°C

Communication	
Communication ports	RS232, RS422, USB, RS485 Profibus, TCP/IP, Ethernet/IP
Inputs-outputs	8/8
External keyboard input	USB
PC software	Creation of marking files, transfer controller / PC or USB key

Optional communication cards:



## PC UTILITIES

### File editor

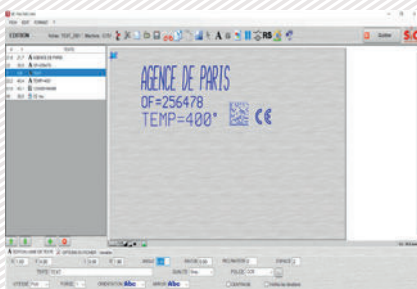

+ Creation or modification of files on PC.

### Creation of logos



+ Creation of vector and matrix logos.

### Creation of logos

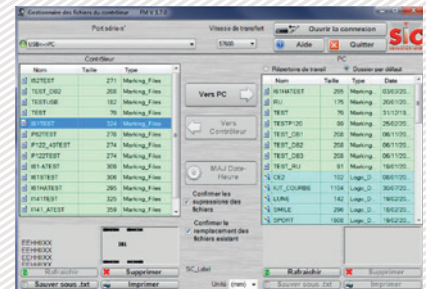

+ Backup and file transfer utility.

# E 10 RANGE SOFTWARE

## Software features

Text function	Incrementation, date codes
Logos	Download from a PC or USB key
Datamatrix	Up to 348 characters, 48 x 48 dots
Fonts	Arial, Comic, Comic_B, Courier, OCR, OCR_BOLD, OCRA, 4x6
Style	Angular, Radial, Inverse, and Mirror
Character Size	From 0,1 mm to 99 mm (limited following marking window)
Depth	Up to 0,3 mm (according to the material)
Resolution Between Dots	0,05 mm MAX
Password	2 security levels
History function	Exportable Excel file
Help with maintenance	Auto diagnosis
Available languages	17



Graphic view



Edit menu

AFFECTATION DES I/O		
Num	Entrée	Sortie
1	ARRET	Cycle
2	DEPART	Dernier
3	Sel. Fich	Erreur
4	Sel. Fich	Pause
5	Sel. Fich	Prêt
6	Sel. Fich	PasPièce
7	Sel. Fich	Pièce
8	Sel. Fich	Usure

STATISTIQUES CONTROLEUR		
Déplacements	Mémoire	
0 Cycles	33 Fichiers	
0 Caractères	17959 o. Utili.	
AXE X 0.0 m	46409 o. Libres	
AXE Y 0.0 m	27% Utilisées	
AXE Z Num. 0.0 m		
Impacts		
F1: 0	F4: 0	F7: 0
F2: 0	F5: 0	F8: 0
F3: 0	F6: 0	F9: 0

PC software for directly controlling the marking machine.

Available functions:

- Editing of marking files
- Input / output management
- History function and anti duplicates
- Datamatrix ECC200 and UID
- ...

# OPTIONAL WINSIC SOFTWARE

WINSIC is a PC software for direct control of the marking machine.

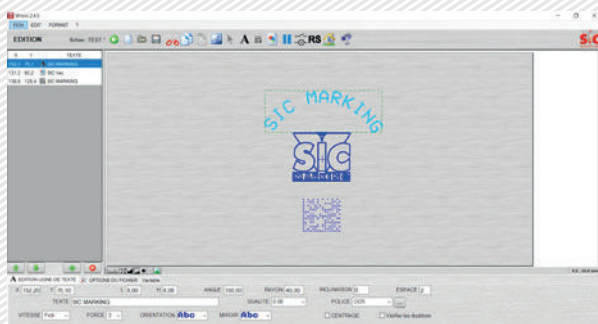

+ Built-in logo design utility

+ Database Management (Excel, Access, txt)

+ Insertion of background images

